



### DC-UPS

- Requires only one 12V battery
- Regulated output voltage in buffer mode
- Compact, width only 49mm
- 50% power reserves
- Low voltage drop between input and output
- Electronically protected against output overloads
- Extensive battery management including battery quality and installation tests
- Soft charger for optimum battery life
- Extensive diagnostic and monitoring functions
- Selectable buffer time limiter
- 3 Year warranty

## 1. GENERAL DESCRIPTION

Power failures or voltage fluctuations can cause damage and downtime, which usually costs a lot of time and money. The UB10.241 together with a battery module offers a reliable and economical protection for 24V applications.

The output is isolated from the input, which allows an easy separation of buffered and non-buffered branches. The energy of the battery will not be wasted by uncritical consumers.

In times when the power supply provides sufficient voltage, the DC-UPS charges the 12V battery. In case the input power fails, the battery voltage will be boosted to a 24V level and the energy will be released in a regulated process to the load.

The included battery management incorporates a battery charger, a deep-discharge protection and an overload protection to achieve a long service life of the battery.

The availability of the DC-UPS is reported by lamps and relay contacts. The DC-UPS automatically checks the installation, the battery fuse and the quality and presence of the battery. Diagnosis is very easy, thanks to clear understandable indicators and relay contacts for remote signaling.

Extensive protection features protect the unit against wrong battery polarity, wrong battery voltage, wrong input voltage or output overloads.

## 2. SHORT-FORM DATA

Operating voltage	DC 24V	
Voltage range	22.5-30Vdc	
Output voltage	22.4V ±2%	Buffer mode
Voltage drop IN/OUT	< 0.3V at 10A	Normal mode
Output current	0 to 15A	Normal mode
	0 to 10A, cont.	Buffer mode
	0 to 15A, for 5s	Buffer mode
Input current	typ. 0.12A *)	Standby mode
	max. 1.1A *)	Charging mode
*) add output current to calculate the total input current		
Charging current	typ. 1.5A	into 12V battery
Charging time	typ. 5h	12V, 7Ah battery
Cut-in threshold	typ. 22.5V	
Power losses	2.7W	Standby mode
	4.6W	10A, Normal mode
Buffer time	min. 6' 15"	at 10A, 7Ah battery
	typ. 8' 30"	at 10A, 7Ah battery
	typ. 32'	at 4A, 7Ah battery
Allowed batteries	>3.9Ah, < 27Ah	VRLA batteries
Temperature range	-25°C...+60°C	operational
Derating	0.25A/°C	+60 to +70°C
Dimensions	49x124x117mm	WxHxD
Weight	530g	

## 3. ORDER NUMBERS

DC-UPS	<b>UB10.241</b>	24V, 10A
Accessory	UZK12.07	12V, 7Ah Battery module
	ZM1.WALL	Wall mounting bracket

## 4. MARKINGS



### INDEX PAGE

1. General Description .....	1
2. Short-form Data .....	1
3. Order Numbers.....	1
4. Markings .....	1
5. Functional Diagram.....	3
6. Wiring Instructions.....	3
7. Required Settings before Use.....	4
8. Buffer Time .....	4
9. Front Side and User Elements.....	5
10. Battery Quality Test .....	6
11. Check Wiring Test .....	6

### INDEX PAGE

12. Relay Contacts and Inhibit Input .....	6
13. Terminals and Wiring .....	7
14. Reliability.....	8
15. EMC.....	8
16. Environment.....	9
17. Protection Features.....	9
18. Safety .....	10
19. Approvals.....	10
20. Fulfilled Standards .....	10
21. Physical Dimensions and Weight .....	11
22. Installation Notes.....	11

## TERMINOLOGY AND ABBREVIATIONS

- Normal Mode** Describes a condition where the battery is fully charged, the input voltage is in range and the output is loaded within the allowed limits.
- Buffer Mode** Describes a condition where the input voltage is below the cut-in threshold, the unit is buffering and the output is loaded within the allowed limits.
- Charging Mode** Describes a condition where the battery is charging, the input voltage is in range and the output is loaded within the allowed limits.

## DISCLAIMER

The information presented in this document is believed to be accurate and reliable and may change without notice.

### 5. FUNCTIONAL DIAGRAM

Fig. 5-1 Functional diagram

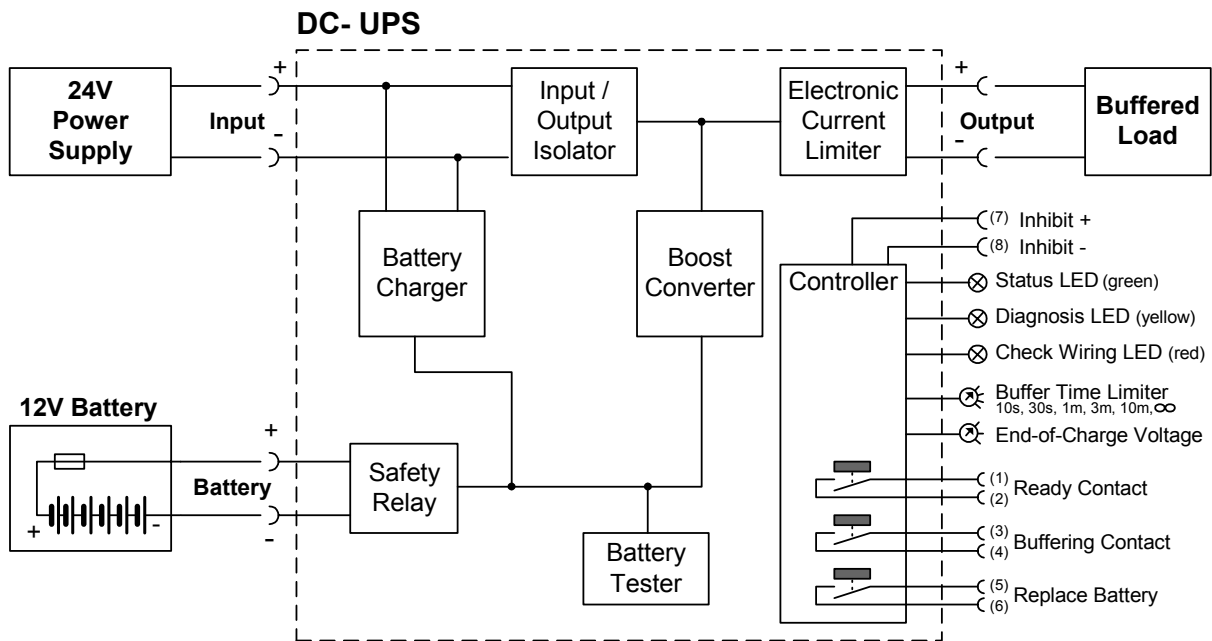

### 6. WIRING INSTRUCTIONS

Fig. 6-1 Wiring diagram

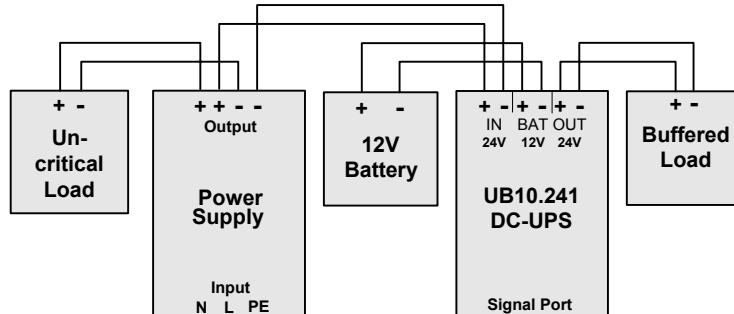

- Connect the power supply to the „Input“ terminals of the DC-UPS
- Connect either a 12V VRLA battery with a capacity between 3.9 and 27Ah or our battery module UZK12.07 to the “Battery” terminals of the DC-UPS. Use wires not smaller than 2.5mm<sup>2</sup> (or 12 AWG) and not longer than 1.5m (single length). Use a 30A fuse Typ ATO® 257 030 (Littelfuse) or the like. The battery fuse protects the wires between the battery module and the DC-UPS, which is recommended, when working on the battery or DC-UPS.
- Connect the buffered load to the “Output” terminals of the DC-UPS. Uncritical loads can be connected directly to the power supply.

## 7. REQUIRED SETTINGS BEFORE USE

### Setting the buffering timer:

The unit is equipped with a buffering timer, which limits the max. buffer time to save battery capacity. The rotary switch on the front allows the setting of a timer to the following 6 steps:

- Indefinite timer deactivated, buffering until the deep discharge protection stops the buffer mode.
- 10 Seconds
- 30 Seconds
- 1 Minute
- 3 Minutes
- 10 Minutes

If the DC voltage recovers within this period of time, the buffering stops immediately.

### Setting the end-of-charge voltage:

The end-of-charge voltage depends on the battery temperature and has a major influence on the life of the battery. The potentiometer on the front of the unit allows an adjustment of the expected battery temperature:

- 10°C → end-of-charge voltage 13,92V ±0,1V
- 20°C → end-of-charge voltage 13,74V ±0,1V
- 30°C → end-of-charge voltage 13,56V ±0,1V
- 40°C → end-of-charge voltage 13,38V ±0,1V

## 8. BUFFER TIME

Fig. 8-1 Hold-up time vs. output current with the battery module UZK12.07 (12V, 7,5Ah)

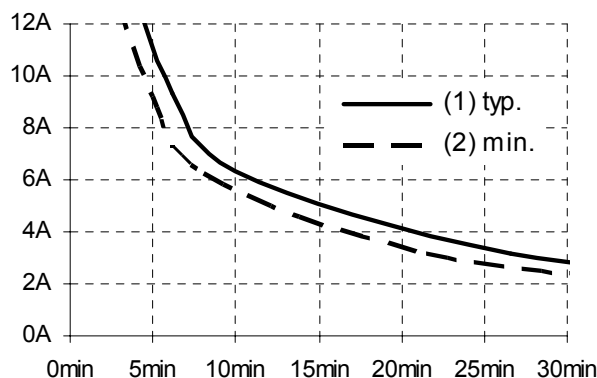

### 9. FRONT SIDE AND USER ELEMENTS

#### Power Port

Quick-connect spring-clamp terminals. Connections for:

- Input voltage
- Battery and
- Output voltage.

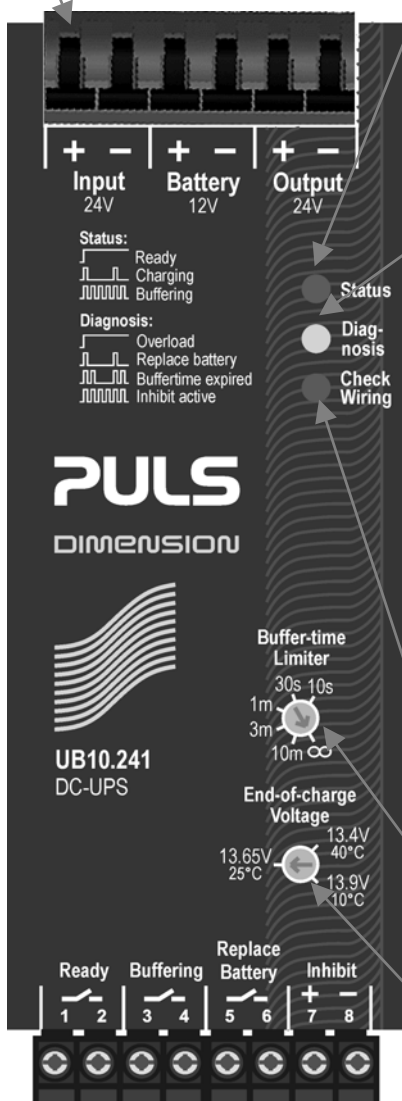

#### The green LED shows the status of the DC-UPS

- **Ready:** Battery is charged > 85%, no wiring failure is recognized, input voltage is sufficient and inhibit signal is not active.
- **Charging:** Battery is charging, battery capacity is below 85%
- **Buffering:** Unit is in buffer mode

Flashing pattern of the green status LED:

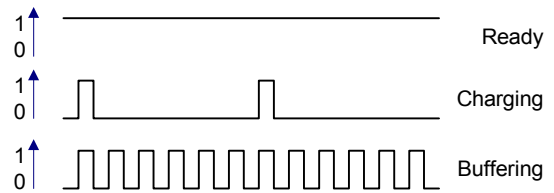

The **yellow diagnosis LED** displays warnings and gives further information about the DC-UPS.

- **Overload:** Output has switched off, due to long overload in buffer mode or due to too high temperatures
- **Replace battery:** Indicates a battery, which failed the battery quality test (SOH test) Battery shall be replaced soon.
- **Buffer-time expired:** Output has switched off, due to settings of buffer timer or due to the deep discharge protection. The signal will be stored and displayed for 15 minutes.
- **Inhibit active:** Indicates that buffering is disabled, due to an active inhibit signal.

Flashing pattern of the yellow diagnosis LED:

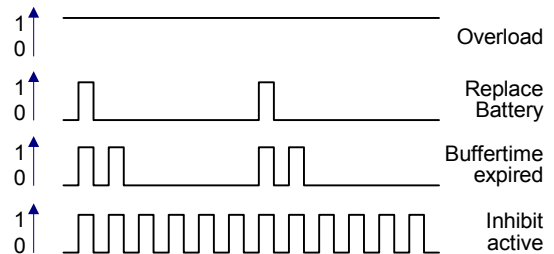

The **red check wiring LED** indicates a failure in the installation, wiring, battery or battery fuse.

#### Buffer time limiter:

User accessible switch, which limits the maximum buffer time in a buffer event to save battery capacity.

#### End-of-charge voltage:

User accessible potentiometer to set the end-of-charge voltage. Adjust the potentiometer according to the expected battery temperature.

#### Signal Port

Plug Connector inserted from the bottom. Connections for:

- Ready relay contact (1-2)
- Buffering relay contact (3-4)
- Replace Battery relay contact (5-6)
- Inhibit input signal (7-8)

### 10. BATTERY QUALITY TEST

The quality of the battery will be checked periodically. A negative result (usually caused by *aged* batteries) will be displayed with a special blinking pattern on the yellow diagnosis LED on the front of the unit.

Once the battery quality test indicates a bad quality of the battery, it is recommended to change the battery as soon as possible

A replacement for the battery can be ordered from PULS under UZB12.07.

### 11. CHECK WIRING TEST

The wiring between the battery and the DC-UPS will be checked periodically. In case of a loose connection, a defective wire, a defective fuse, a wrong battery, a fatal failure of the battery or a reverse battery polarity will be displayed with the red "Check Wiring" LED on the front of the unit.

### 12. RELAY CONTACTS AND INHIBIT INPUT

Ready Relay (Pin 1&2)	Contact is closed when battery is charged more than 85%, no wiring failure is recognized, input voltage is sufficient and inhibit signal is not active.
Buffering Relay (Pin 3&4)	Contact is closed when unit is buffering.
Replace Battery (Pin 5&6)	Contact is closed when input voltage is sufficient and battery quality test (SOH test) indicates that the battery should be replaced.

Relay contact ratings	max	60Vdc 0.3A, 30Vdc 1A, 30Vac 0.5A resistive load
	min	1mA at 5Vdcmin.
Isolation voltage	max	500Vac, signal port to power port

Inhibit input (Pin 7&8)	The inhibit input disables buffering. In normal mode, a static signal is required. In buffer mode, a pulse with a minimum length of 250ms is required to stop buffering. The inhibit is stored and can be reset by cycling the input voltage.
-------------------------	---

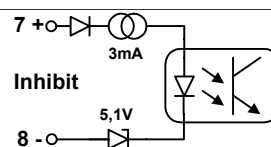

Signal voltage	max.	35Vdc
Signal current	max.	4mA, current limited
Inhibit threshold	min.	6Vdc, buffering is enabled above this threshold level
	max.	10Vdc
Isolation	nom.	500Vac, signal port to power port

### 13. TERMINALS AND WIRING

#### Power terminals

Type	Bi-stable, quick-connect spring clamp terminals. IP20 Finger safe construction. Suitable for field- and factory installation. Shipped in open position.
Solid wire	0.5-6mm <sup>2</sup>
Stranded wire	0.5-4mm <sup>2</sup>
AWG	20-10AWG
Ferrules	Allowed, but not required
Pull-out force	10AWG:80N, 12AWG:60N, 14AWG:50N, 16AWG:40N (according to UL486E)
Wire stripping length	10mm / 0.4inch

#### Instructions:

- Use appropriate copper cables, that are designed for an operating temperature of 60°C
- Follow national installation codes and regulations!
- Ensure that all strands of a stranded wire enter the terminal connection!
- Up to two stranded wires with the same cross section are permitted in one connection point

Fig. 13-1 Connecting a wire

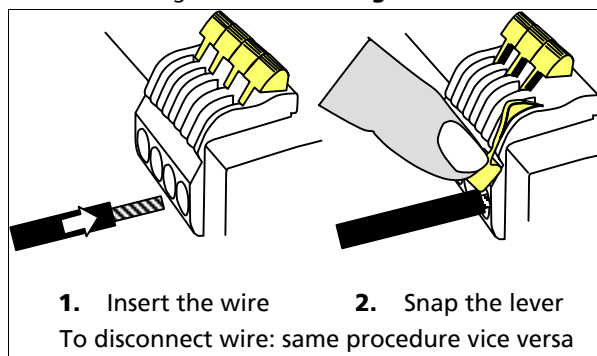

#### Signal terminals

Type	Plug connector with screw terminal mechanism. Finger-touch-proof terminal with captive screws for 3.5mm slotted screwdriver.
Solid / stranded wire	0.2-1.5mm <sup>2</sup>
AWG	22-14AWG
Ferrules	up to 1.5 mm <sup>2</sup> wire gauge
Wire stripping length	6mm / 0.24inch
Tightening torque	0.4Nm, 3.5lb.in

### 14. RELIABILITY

Lifetime expectancy	min.	T.b.d.	40°C, normal mode
	min.	T.b.d.	25°C, normal mode
MTBF SN 29500, IEC 61709		T.b.d.	40°C, normal mode
		T.b.d.	25°C, normal mode
		T.b.d.	40°C, buffer mode
		T.b.d.	25°C, buffer mode
MTBF MIL HDBK 217F		T.b.d.	40°C, normal mode, ground benign GB40
		T.b.d.	25°C, normal mode, ground benign GB25
		T.b.d.	40°C, buffer mode, ground benign GB40
		T.b.d.	25°C, buffer mode, ground benign GB25

The **Lifetime expectancy** shown in the table indicates the operating hours (service life) and is determined by the lifetime expectancy of the built-in electrolytic capacitors. Lifetime expectancy is specified in operational hours. Lifetime expectancy is calculated according to the capacitor’s manufacturer specification.

**MTBF** stands for **Mean Time Between Failure**, which is calculated according to the statistically device failures, and indicates reliability of a device. It is the statistical representation of the likelihood of a unit to fail and does not necessarily represent a life of a product.

### 15. EMC

The unit is suitable for applications in industrial environment as well as in residential, commercial and light industry environment without any restrictions. CE mark is in conformance with EMC guideline 89/336/EEC and 93/68/EEC and the low-voltage directive (LVD) 73/23/EWG.

A detailed EMC Report is available on request

EMC Immunity	EN 61000-6-1 EN 61000-6-2		Generic standards	
Electrostatic discharge 1)	EN 61000-4-2	Contact discharge	8kV	Criterion A
		Air discharge	15kV	Criterion A
Electromagnetic RF field	EN 61000-4-3	80MHz-1GHz	10V/m	Criterion A
Fast transients (Burst)	EN 61000-4-4		2kV	Criterion A
Surge voltage	EN 61000-4-5	+ → -	500V	Criterion A
		+ / - → housing	500V	Criterion A
Conducted disturbance	EN 61000-4-6	0,15-80MHz	10V	Criterion A

1) Din-Rail earthed

EMC Emission	EN 61000-6-3 and EN 61000-6-4		Generic standards	
Conducted emission	EN 55022		Class B	
Radiated emission	EN 55011, EN 55022		Class B	

This device complies with FCC Part 15 rules.

Operation is subjected to following two conditions: (1) this device may not cause harmful interference, and (2) this device must accept any interference received, including interference that may cause undesired operation.



### 16. ENVIRONMENT

Operational temperature	-25°C to +70°C	full power, for the DC-UPS control unit, keep battery in a cold environment!
Derating	0,25A/°C 0,43A/°C	+60°C...+70°C, buffer mode see Fig. 16-2 +60°C...+70°C, normal mode see Fig. 16-1
Storage temperature	-40 to +85°C	storage and transportation, except battery
Humidity	5 to 95% r.H.	IEC 60068-2-30 Do not energize while condensation is present
Vibration sinusoidal	2-17.8Hz: ±1.6mm; 17.8-500Hz: 2g	IEC 60068-2-6
Vibration random	0.5m <sup>2</sup> (s <sup>3</sup> )	IEC 60068-2-64
Shock	30g 6ms, 20g 11ms	IEC 60068-2-27
Altitude	0 to 6000m	Approvals apply only up to 2000m
Over-voltage category	III II	EN 50178 EN 50178 above 2000m altitude
Degree of pollution	2	EN 50178, not conductive

Fig. 16-1 Output current in normal mode vs. ambient temp.

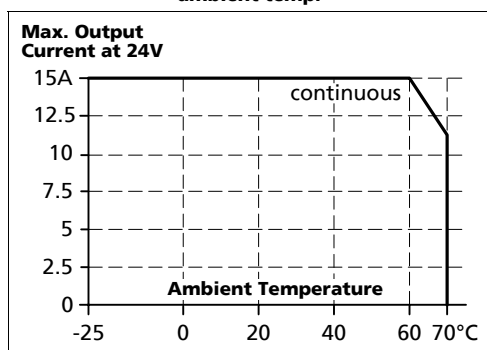
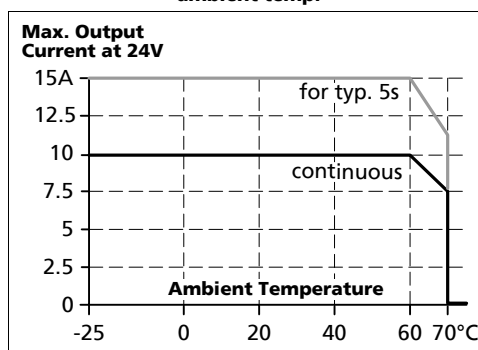

Fig. 16-2 Output current in buffer mode vs. ambient temp.



The ambient temperature is defined 2cm below the unit.

### 17. PROTECTION FEATURES

Output protection	Electronically protected against overload, no-load and short-circuits
Output over-voltage protection in buffer mode	typ. 32Vdc max. 35Vdc In case of an internal defect, a redundant circuitry limits the maximum output voltage. The output automatically shuts-down and makes restart attempts.
Degree of protection	IP 20 EN/IEC 60529
Penetration protection	> 3.5mm e.g. screws, small parts
Reverse battery polarity protection	yes max. -35Vdc
Wrong battery voltage protection	yes max. +35Vdc (e.g. 24V instead of 12V)
Battery deep discharge protection	yes limit is battery current dependent
Over temperature protection	yes output shut-down with automatic restart
Input over-voltages protection	yes max. 35Vdc, no harm or defect of the unit
Internal input fuse	20A no user accessible part, no service part

### 18. SAFETY

Output voltage	SELV PELV	IEC/EN 60950-1 EN 60204-1, EN 50178, IEC 60364-4-41
Class of protection	II	
Isolation resistance	> 5MΩ	Power port to housing, 500Vdc
PE resistance	< 0.1Ω	between housing and chassis ground terminal
Dielectric strength	500Vac 500Vac	Power port to signal port Power port / signal port to housing

### 19. APPROVALS

UL 508 pending		LISTED E198865 listed for use in U.S.A. (UL 508) and Canada (C22.2 No. 14-95) Industrial Control Equipment
UL 60950-1 pending		RECOGNIZED E137006 recognized for the use in U.S.A. (UL 60950-1) and Canada (C22.2 No. 60950) Information Technology Equipment, Level 5
IEC 60950-1 pending		CB Scheme, Information Technology Equipment
Marine pending		GL (Germanischer Lloyd) classified and ABS (American Bureau for Shipping) PDA for marine and offshore applications. Environmental category: C, EMC2

### 20. FULFILLED STANDARDS

EN/IEC 60204-1	Safety of Electrical Equipment of Machines
EN/IEC 61131	Programmable Controllers
EN 50178	Electronic Equipment in Power Installations

## 21. PHYSICAL DIMENSIONS AND WEIGHT

Width	49mm / 1.93"	
Height	124mm / 4.88"	plus height of signal connector
Depth	117mm / 4.61"	plus depth of DIN-rail
Weight	530g / 1.17lb	
DIN-Rail	Use DIN-rails according to EN 60715 or EN 50022 with a height of 7.5 or 15mm	

Fig. 21-1 Side view

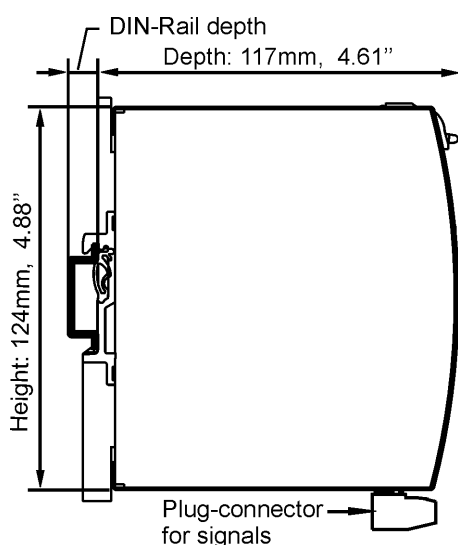
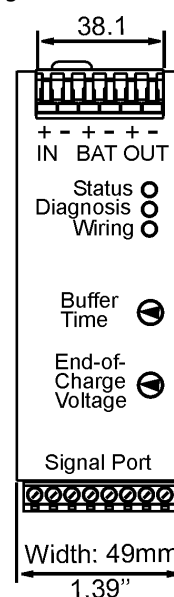

Fig. 21-2 Front view



## 22. INSTALLATION NOTES

### Cable to connect the battery

Use wires not smaller than 2.5mm<sup>2</sup> (or 12 AWG) and not longer than 2x1.5m. Use a 30A battery fuse typ ATO® 257 030 (Littelfuse) or the like. The battery fuse protects the wires between the battery module and the DC-UPS. Furthermore, it allows the disconnection of the battery from the DC-UPS, which is recommended, when working on the battery or DC-UPS.

### Mounting orientation

The power terminal shall be located on top of the unit.

### Cooling

Convection cooled, no forced air cooling required. Do not obstruct air flow!

### Installation clearances:

No special installation clearances are necessary

### Intended use

This DC-UPS has been designed for use in panel board installations or other building-in applications where a suitable mechanical enclosure shall be provided to fulfil local requirements.

### Service parts:

The unit does not contain any service parts. If damage or malfunctioning should occur during operation, immediately turn power off and send unit for inspection to factory!